

**Question 1–30 Carry One Mark Each**

1. The following differential equation has

$$3 \frac{d^2 y}{dt^2} + 4 \left( \frac{dy}{dt} \right)^3 + y^2 + 2 = x$$

- (A) degree = 2, order = 1  
 (B) degree = 3, order = 2  
 (C) degree = 4, order = 3  
 (D) degree = 2, order = 3
2. Choose the function  $f(t)$ ;  $-\infty < t < \infty$ , for which a Fourier series cannot be defined.  
 (A)  $3 \sin(25t)$   
 (B)  $4 \cos(20t + 3) + 2 \sin(710t)$   
 (C)  $\exp(-|t|) \sin(25t)$   
 (D) 1
3. A fair dice is rolled twice. The probability that an odd number will follow an even number is

- (A)  $\frac{1}{2}$   
 (B)  $\frac{1}{6}$   
 (C)  $\frac{1}{3}$   
 (D)  $\frac{1}{4}$

4. A solution of the following differential equation is given by

$$\frac{d^2 y}{dx^2} - 5 \frac{dy}{dx} + 6y = 0$$

- (A)  $y = e^{2x} + e^{-3x}$   
 (B)  $y = e^{2x} + e^{3x}$   
 (C)  $y = e^{-2x} + e^{3x}$   
 (D)  $y = e^{-2x} + e^{-3x}$
5. The function  $x(t)$  is shown in the figure. Even and odd parts of a unit-step function  $u(t)$  are respectively,

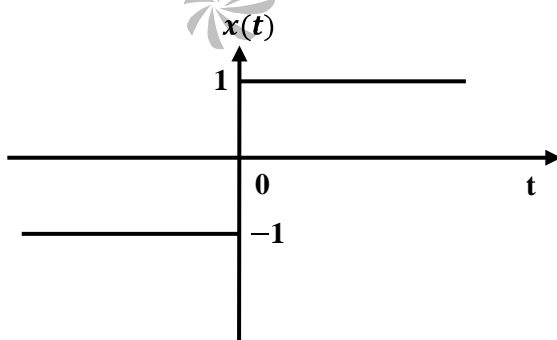

- (A)  $\frac{1}{2}, \frac{1}{2}x(t)$   
 (B)  $-\frac{1}{2}, \frac{1}{2}x(t)$   
 (C)  $\frac{1}{2}, -\frac{1}{2}x(t)$   
 (D)  $-\frac{1}{2}, -\frac{1}{2}x(t)$

6. The region of convergence of Z-transform of the sequence

$$\left(\frac{5}{6}\right)^n u(n) - \left(\frac{6}{5}\right)^n u(-n-1) \text{ must be}$$

- (A)  $|z| < \frac{5}{6}$   
 (B)  $|z| > \frac{6}{5}$   
 (C)  $\frac{5}{6} < |z| < \frac{6}{5}$   
 (D)  $\frac{6}{5} < |z| < \infty$
7. The condition on R, L and C such that the step response  $y(t)$  in the figure has no oscillations, is

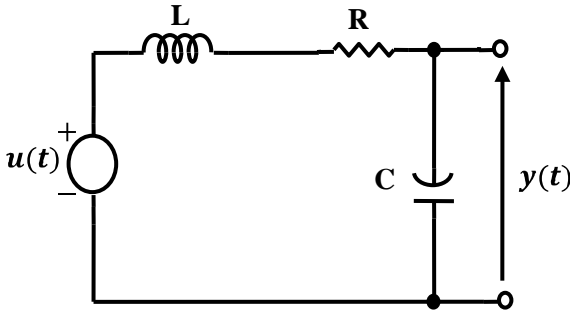

- (A)  $R \geq \frac{1}{2} \sqrt{\frac{L}{C}}$   
 (B)  $R \geq \sqrt{\frac{L}{C}}$   
 (C)  $R \geq 2 \sqrt{\frac{L}{C}}$   
 (D)  $R \geq \frac{1}{\sqrt{LC}}$
8. The ABCD parameters of an ideal  $n:1$  transformer shown in the figure are  $\begin{bmatrix} n & 0 \\ 0 & X \end{bmatrix}$ . The value of X will be

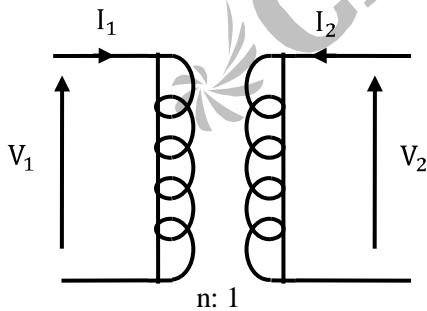

- (A)  $n$   
 (B)  $\frac{1}{n}$   
 (C)  $n^2$   
 (D)  $\frac{1}{n^2}$

9. In a series RLC circuit,  $R = 2 \text{ k}\Omega$ ,  $L = 1\text{H}$ , and  $C \frac{1}{400} = \mu\text{F}$ . The resonant frequency is  
 (A)  $2 \times 10^4 \text{ Hz}$   
 (B)  $\frac{1}{\pi} \times 10^4 \text{ Hz}$   
 (C)  $10^4 \text{ Hz}$   
 (D)  $2\pi \times 10^4 \text{ Hz}$
10. The maximum power that can be transferred to the load resistor  $R_L$  from the voltage source in the figure is

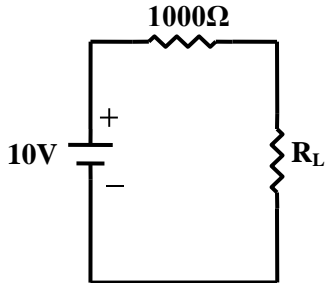

- (A) 1W  
 (B) 10W  
 (C) 0.25W  
 (D) 0.5W
11. The bandgap of silicon at room temperature is  
 (A) 1.3 eV  
 (B) 0.7 eV  
 (C) 1.1 eV  
 (D) 1.4 eV
12. A silicon PN junction at a temperature of  $20^0 \text{ C}$  has a reverse saturation current of 10 pico-Amperes (pA). The reverse saturation current at  $40^0 \text{ C}$  for the same bias is approximately  
 (A) 30 pA.  
 (B) 40 pA.  
 (C) 50pA.  
 (D) 60pA
13. The primary reason for the widespread use of Silicon in semiconductor device technology is  
 (A) abundance of Silicon on the surface of the Earth.  
 (B) larger bandgap of Silicon in comparison to Germanium.  
 (C) favorable properties of Silicon–dioxide ( $\text{SiO}_2$ ).  
 (D) lower melting point.
14. The effect of current shunt feedback in an amplifier to  
 (A) increase the input resistance and decrease the output resistance.  
 (B) increase both input and output resistances.  
 (C) decrease both input and output resistances.  
 (D) decrease the input resistance and increase the output resistance.

15. The input resistance  $R_i$  of the amplifier shown in the figure is

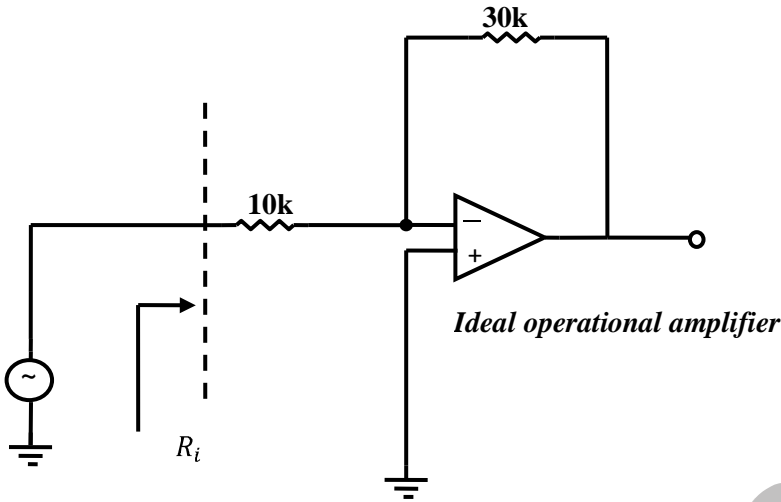

- (A)  $\frac{30}{4} \text{ k}\Omega$  (C)  $40 \text{ k}\Omega$   
 (B)  $10 \text{ k}\Omega$  (D) Infinite
16. The first and the last critical frequency of an RC-driving point impedance function must respectively be  
 (A) a zero and a pole (C) a pole and a pole  
 (B) a zero and a zero (D) a pole and a zero
17. The cascode amplifier is a multistage configuration of  
 (A) CC-CB (C) CB-CC  
 (B) CE-CB (D) CE-CC
18. Decimal 43 in Hexadecimal and BCD number system is respectively  
 (A) B2, 0100 0011 (C) 2B, 0011 0100  
 (B) 2B, 0100 0011 (D) B2, 0100 0100
19. The Boolean function  $f$  implemented in the figure using two input multiplexers is

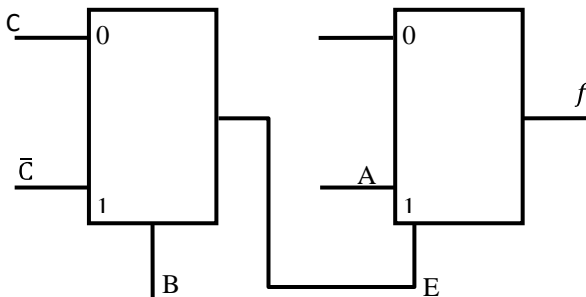

(A)  $A\bar{B}C + AB\bar{C}$

(C)  $\bar{A}BC + \bar{A}\bar{B}C$

(B)  $ABC + A\bar{B}\bar{C}$

(D)  $\bar{A}\bar{B}C + \bar{A}B\bar{C}$

20. Which of the following can be impulse response of a casual system?

(A)

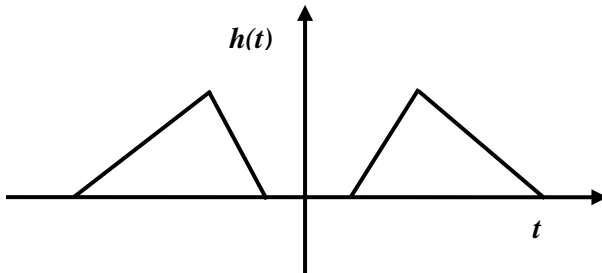

(B)

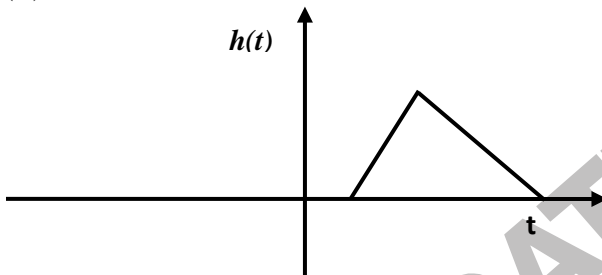

(C)

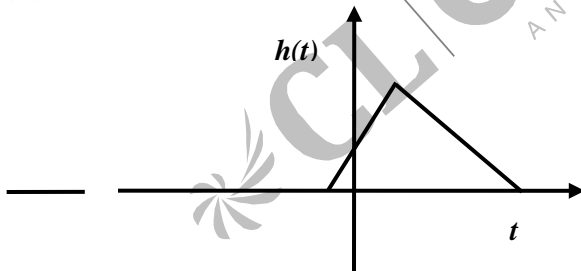

(D)

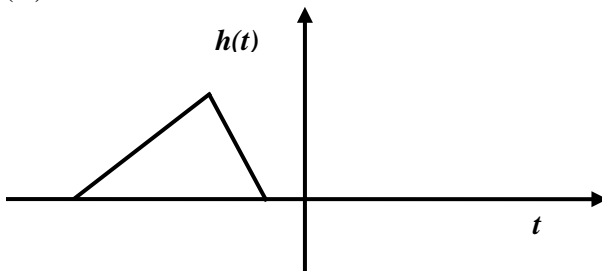

21. Let  $x(n) = \left(\frac{1}{2}\right)^n u(n)$ ,  $y(n) = x^2(n)$  and  $Y(e^{j\omega})$  be the Fourier transform of  $y(n)$ . Then  $Y(e^{j0})$  is

- (A)  $\frac{1}{4}$   
 (B) 2  
 (C) 4  
 (D)  $\frac{4}{3}$

22. Find the correct match between group 1 and group 2.

**Group I**

- P** -  $\{1 + km(t)\} A \sin(\omega_c t)$   
**Q** -  $km(t) A \sin(\omega_c t)$   
**R** -  $A \sin\{\omega_c t + km(t)\}$   
**S** -  $A \sin\left[\omega_c t + k \int_{-\infty}^t m(t) dt\right]$

**Group II**

- W** - Phase modulation  
**X** - Frequency modulation  
**Y** - Amplitude modulation  
**Z** - DSB-SC modulation

- (A) P-Z, Q-Y, R-X, S-W, (C) P-X, Q-W, R-Z, S-Y,  
 (B) P-W, Q-X, R-Y, S-Z, (D) P-Y, Q-Z, R-W, S-X,

23. The power in the signal  $s(t) = 8 \cos\left(20\pi t - \frac{\pi}{2}\right) + 4 \sin(15\pi t)$  is

- (A) 40 (C) 42  
 (B) 41 (D) 82

24. Which of the following analog modulation scheme requires the minimum transmitted power and minimum channel bandwidth?

- (A) VSB (C) SSB  
 (B) DSB-SC (D) AM

25. A linear system is equivalently represented by two sets of state equations.  $\dot{X} = AX + BU$  and  $\dot{W} = CW + DU$ . The eigenvalues of the representations are also computed as  $\{\lambda\}$  and  $\{\mu\}$ . Which one of the following statements is true?

- (A)  $[\lambda] = [\mu]$  and  $X = W$  (C)  $[\lambda] \neq [\mu]$  and  $X = W$   
 (B)  $[\lambda] = [\mu]$  and  $X \neq W$  (D)  $[\lambda] \neq [\mu]$  and  $X \neq W$

26. Which one of the following polar diagrams corresponds to a lag network?

(A)

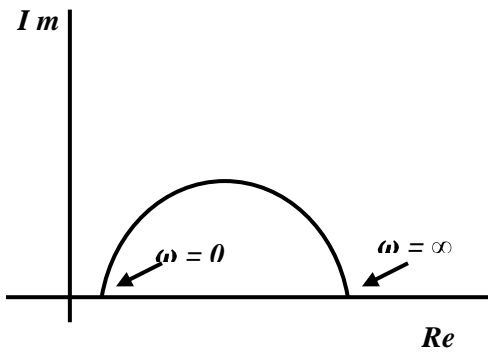

(B)

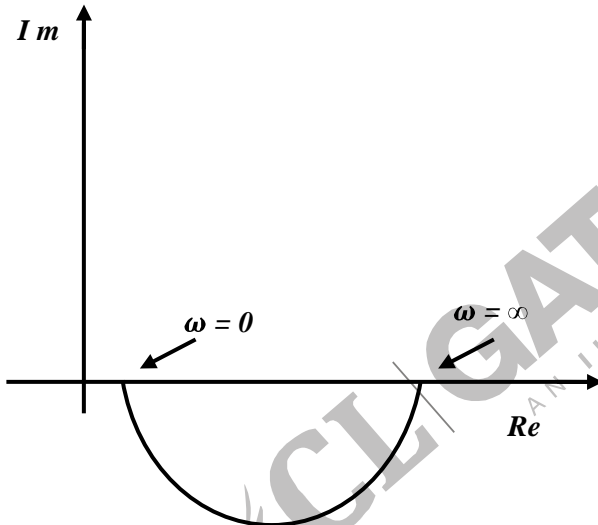

(C)

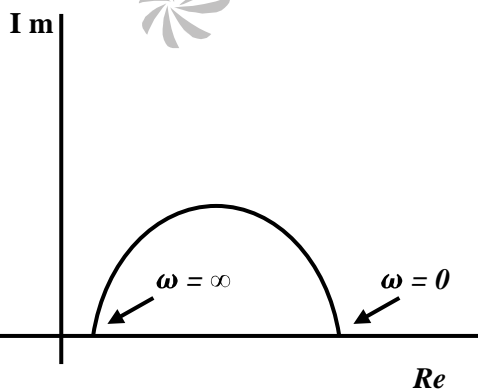

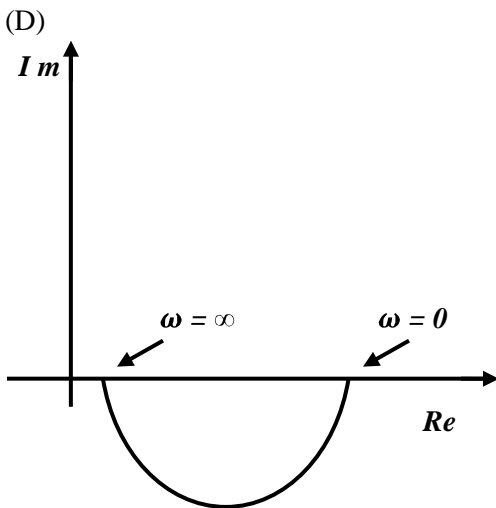

27. Despite the presence of negative feedback, control systems still have problems of instability because the
- (A) components used have nonlinearities.
  - (B) dynamic equations of the subsystems are not known exactly.
  - (C) mathematical analysis involves approximations.
  - (D) system has large negative phase angle at high frequencies.
28. The magnetic field intensity vector of a plane wave is given by  $\vec{H}(x, y, z, t) = 10 \sin(50000t + 0.004x + 30\hat{a}_y)$ , Where  $\hat{a}_y$  denotes the unit vector in  $y$  direction. The wave is propagating with a phase velocity
- (A)  $5 \times 10^4$  m/s.
  - (B)  $-3 \times 10^8$  m/s.
  - (C)  $-1.25 \times 10^7$  m/s.
  - (D)  $3 \times 10^8$  m/s.

29. Many circles are drawn in a Smith chart used for transmission line calculations. The circles shown in the figure represent

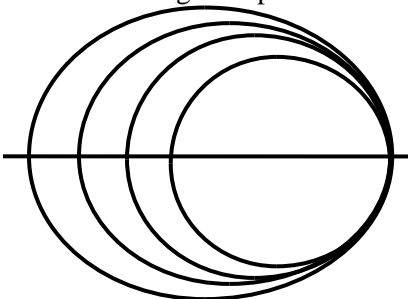

- (A) Unit circles.
- (B) Constant resistance circles.

- (C) Constant reactance circles. (D) Constant reflection coefficient circles.
30. Refractive index of glass is 1.5. Find the wavelength of a beam of light with a frequency of  $10^{14}$  Hz in glass. Assume velocity of light is  $3 \times 10^8$  m/s in vacuum.
- (A) 3  $\mu\text{m}$   
 (B) 3 mm  
 (C) 2  $\mu\text{m}$   
 (D) 1  $\mu\text{m}$

**Question 31–80 Carry Two Marks Each**

31. In what range should  $\text{Re}(s)$  remain so that the Laplace transform of the function  $e^{(a+2)t+5}$  exists?
- (A)  $\text{Re}(s) > a + 2$  (C)  $\text{Re}(s) < 2$   
 (B)  $\text{Re}(s) > a + 7$  (D)  $\text{Re}(s) > a + 5$
32. Given the matrix  $\begin{bmatrix} -4 & 2 \\ 4 & 3 \end{bmatrix}$ , the eigenvector is
- (A)  $\begin{bmatrix} 3 \\ 2 \end{bmatrix}$   
 (B)  $\begin{bmatrix} 4 \\ 3 \end{bmatrix}$   
 (C)  $\begin{bmatrix} 2 \\ -1 \end{bmatrix}$   
 (D)  $\begin{bmatrix} -2 \\ 1 \end{bmatrix}$
33. Let,  $A = \begin{bmatrix} 2 & -0.1 \\ 0 & 3 \end{bmatrix}$  and  $A^{-1} = \begin{bmatrix} \frac{1}{2} & a \\ 0 & b \end{bmatrix}$  Then  $(a + b) =$
- (A)  $\frac{7}{20}$  (C)  $\frac{19}{60}$   
 (B)  $\frac{3}{20}$  (D)  $\frac{11}{20}$
34. The value of the integral  $I = \frac{1}{\sqrt{2\pi}} \int_0^{\infty} \exp\left(-\frac{x^2}{8}\right) dx$  is
- (A) 1 (C) 2  
 (B)  $\pi$  (D)  $2\pi$
35. The derivative of the symmetric function drawn in given figure will look like

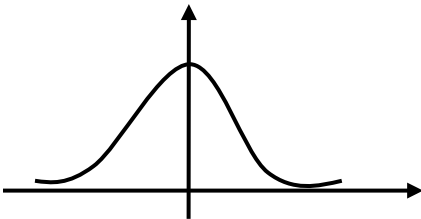

(A)

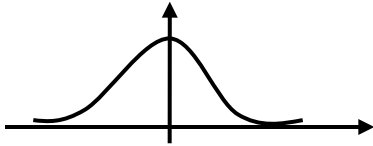

(B)

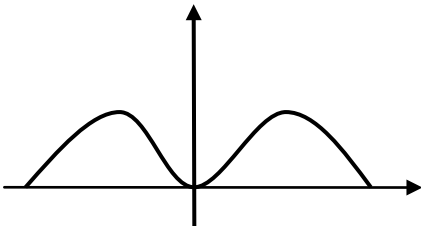

(C)

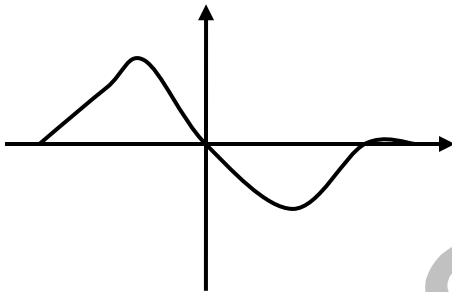

(D)

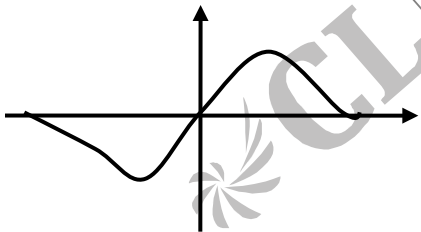

36. Match the following and choose the correct combination :

**Group 1**

- E. Newton–Raphson method
- F. Runge–kutta method
- G. Simpson's Rule
- H. Gauss elimination

- (A) E-6, F-1, G-5, H-3
- (B) E-1, F-6, G-4, H-3

**Group 2**

1. Solving nonlinear equations
2. Solving linear simultaneous equations
3. Solving ordinary differential equations
4. Numerical integration method
5. Interpolation
6. Calculation of Eigenvalues

- (C) E-1, F-3, G-4, H-2
- (D) E-5, F-3, G-4, H-1

37. Given an orthogonal matrix  $A = \begin{bmatrix} 1 & 1 & 1 & 1 \\ 1 & 1 & -1 & -1 \\ 1 & -1 & 0 & 0 \\ 0 & 0 & 1 & -1 \end{bmatrix}$   $[A A^T]^{-1}$  is

(A)  $\begin{bmatrix} \frac{1}{4} & 0 & 0 & 0 \\ \frac{1}{4} & \frac{1}{4} & 0 & 0 \\ 0 & 0 & \frac{1}{2} & \frac{1}{2} \\ 0 & 0 & 0 & \frac{1}{2} \end{bmatrix}$

(B)  $\begin{bmatrix} \frac{1}{2} & 0 & 0 & 0 \\ \frac{1}{2} & \frac{1}{2} & 0 & 0 \\ 0 & 0 & \frac{1}{2} & 0 \\ 0 & 0 & \frac{1}{2} & \frac{1}{2} \end{bmatrix}$

(C)  $\begin{bmatrix} 1 & 0 & 0 & 0 \\ 0 & 1 & 0 & 0 \\ 0 & 0 & 1 & 0 \\ 0 & 0 & 0 & 1 \end{bmatrix}$

(D)  $\begin{bmatrix} \frac{1}{4} & 0 & 0 & 0 \\ \frac{1}{4} & \frac{1}{4} & 0 & 0 \\ 0 & 0 & \frac{1}{4} & \frac{1}{4} \\ 0 & 0 & 0 & \frac{1}{4} \end{bmatrix}$

38. For the circuit show in the figure, the instantaneous current  $i_i(t)$  is

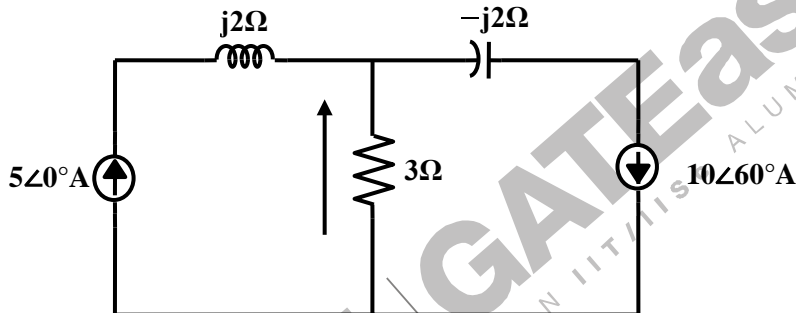

(A)  $\frac{10\sqrt{3}}{2} \angle 90^\circ$  Amps.

(B)  $\frac{10\sqrt{3}}{2} \angle -90^\circ$  Amps.

(C)  $5 \angle 60^\circ$  Amps.

(D)  $5 \angle -60^\circ$  Amps.

39. Impedance  $Z$  as shown in the given figure is

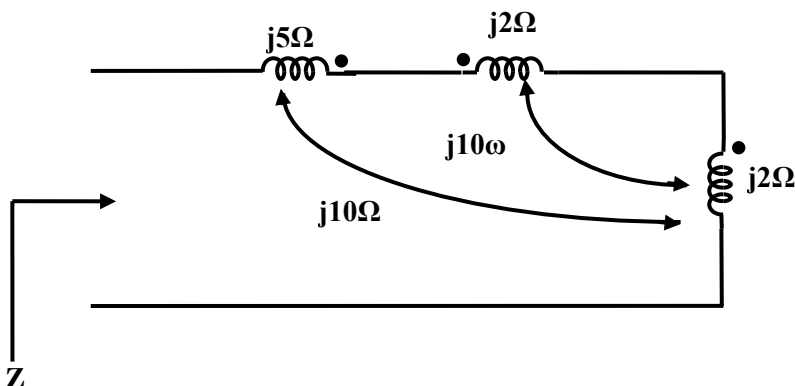

- (A)  $j29\Omega$  (C)  $j19\Omega$   
 (B)  $j9\Omega$  (D)  $j39\Omega$

40. For the circuit shown in the figure, Thevenin's voltage and Thevenin's equivalent resistance at terminals  $a - b$  is

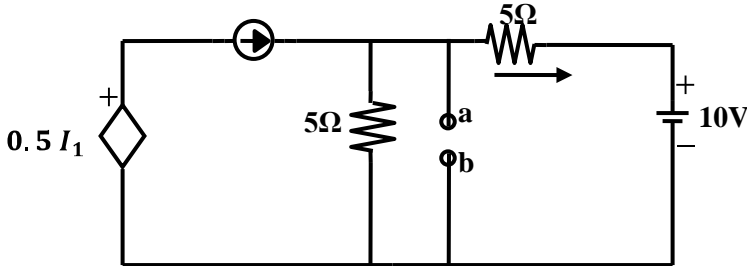

- (A) 5 V and 2  $\Omega$ . (C) 4 V and 2  $\Omega$ .  
 (B) 7.5 V and 2.5  $\Omega$ . (D) 3 V and 2.5  $\Omega$ .

41. If  $R_1 = R_2 = R_4 = R$  and  $R_3 = 1.1R$  in the bridge circuit shown in the figure, then the reading in the ideal voltmeter connected between  $a$  and  $b$  is

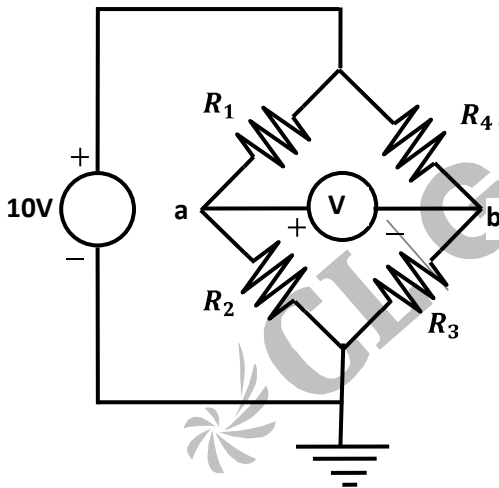

- (A) 0.238 V. (C) -0.238 V.  
 (B) 0.138 V. (D) 1 V.

42. The  $h$  parameters of the circuit shown in the figure are

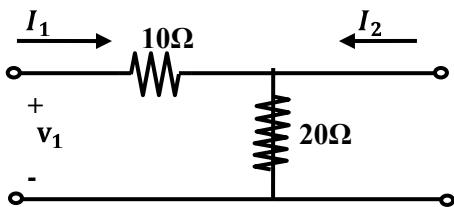

(A)  $\begin{bmatrix} 0.1 & 0.1 \\ -0.1 & 0.3 \end{bmatrix}$   
 (B)  $\begin{bmatrix} 10 & -1 \\ 1 & 0.05 \end{bmatrix}$

(C)  $\begin{bmatrix} 30 & 20 \\ 20 & 20 \end{bmatrix}$   
 (D)  $\begin{bmatrix} 10 & 1 \\ -1 & 0.05 \end{bmatrix}$

43. A square pulse of 3 volts amplitude is applied to C-R circuit shown in the figure. The capacitor is initially uncharged. The output voltage  $V_0$  at time  $t = 2 \text{ sec}$  is

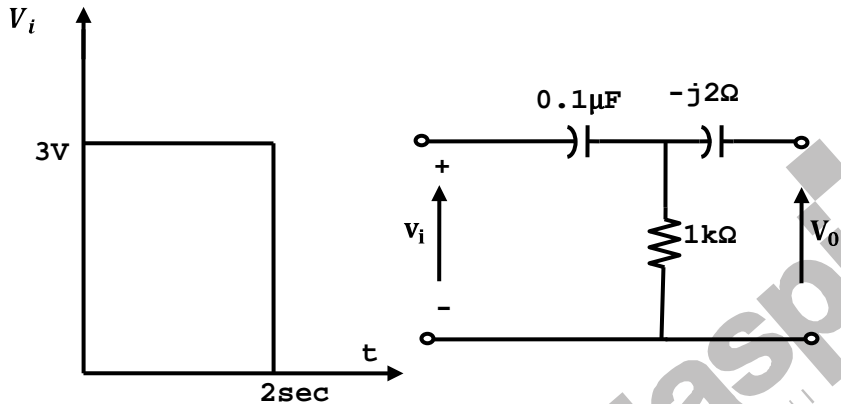

- (A) 3V  
 (B) -3V  
 (C) 4V  
 (D) -4V
44. A Silicon sample A is doped with  $10^{18}$  atoms/cm<sup>3</sup> of Boron. Another sample B of identical dimensions is doped with  $10^{18}$  atoms/cm<sup>3</sup> of Phosphorus. The ratio of electron to hole mobility is 3. The ratio of conductivity of the sample A to B is
- (A) 3  
 (B)  $\frac{1}{3}$   
 (C)  $\frac{2}{3}$   
 (D)  $\frac{3}{2}$
45. A Silicon PN junction diode under reverse bias has depletion region of width  $10 \mu\text{m}$ . The relative permittivity of Silicon,  $\epsilon_r = 11.7$  and the permittivity of free space  $\epsilon_0 = 8.85 \times 10^{-12} \text{ F/m}$ . The depletion capacitance of the diode per square meter is
- (A)  $100 \mu\text{F}$ .  
 (B)  $10 \mu\text{F}$ .  
 (C)  $1 \mu\text{F}$ .  
 (D)  $20 \mu\text{F}$ .
46. For an npn transistor connected as shown in the figure,  $V_{BE} = 0.7$  volts. Given that reverse saturation current of the junction at room temperature  $300^\circ\text{K}$  is  $10^{-13} \text{ A}$ , the emitter current is

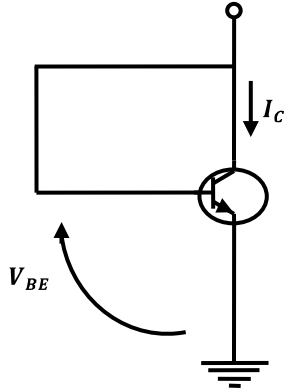

- (A) 30 mA.  
(B) 39 mA.

- (C) 49 mA.  
(D) 20 mA.

47. The voltage  $e_0$  indicated in the figure has been measured by an ideal voltmeter. Which of the following can be calculated?

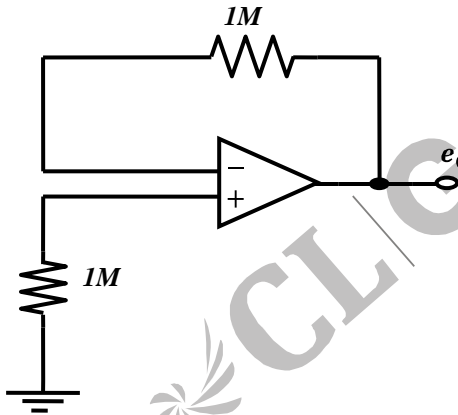

- (A) Bias current of the inverting input only  
(B) Bias current of the inverting and non-inverting inputs only  
(C) Input offset current only  
(D) Both the bias currents and the input offset current.



50. For an n-channel MOSFET and its transfer curve shown in the figure, the threshold voltage is

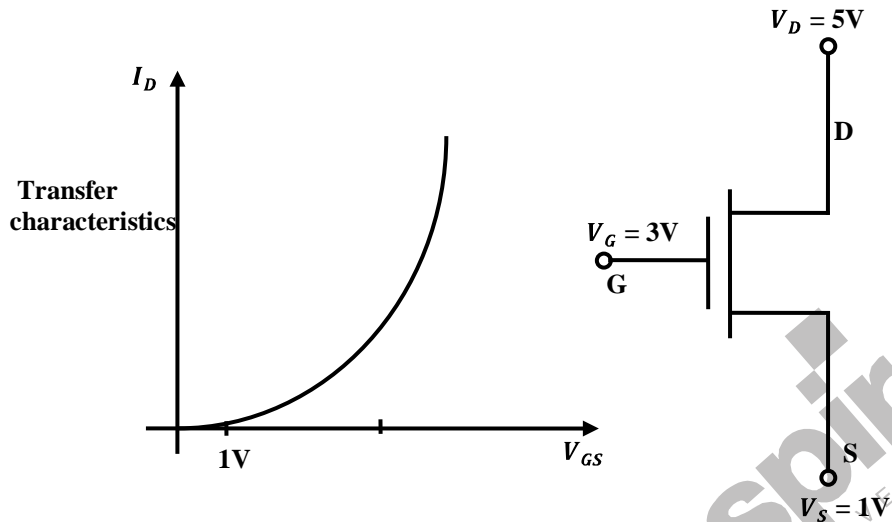

- (A) 1 V and the device is in active region.  
 (B) -1 V and the device is in saturation region.  
 (C) 1 V and the device is in saturation region.  
 (D) -1 V and device is in active region.
51. The circuit using a BJT with  $\beta = 50$  and  $V_{BE} = 0.7V$  is shown in the figure. The base current  $I_B$  and collector voltage  $V_c$  are respectively

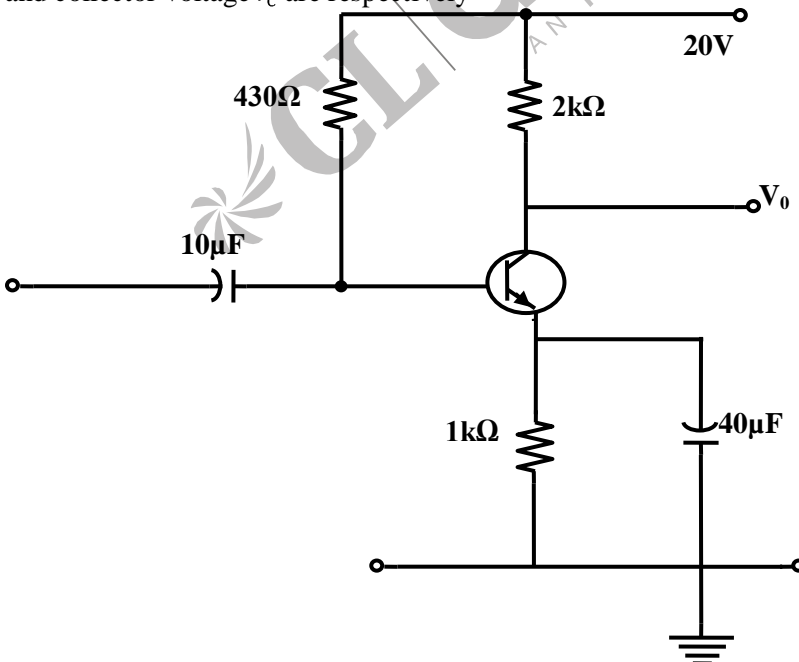

- (A) 43  $\mu\text{A}$  and 11.4 Volts. (C) 45  $\mu\text{A}$  and 11 Volts.  
 (B) 40  $\mu\text{A}$  and 16 Volts. (D) 50  $\mu\text{A}$  and 10 Volts.

52. The zener diode in the regulator circuit shown in the figure has a Zener voltage of 5.8 volts and a Zener knee current of 0.5 mA. The maximum load current drawn from this circuit ensuring proper functioning over the input voltage range between 20 and 30 volts, is

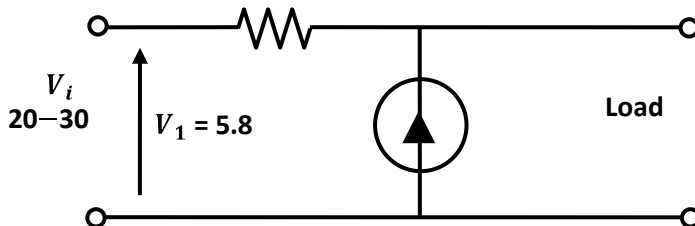

- (A) 23.7 mA. (C) 13.7 mA.  
 (B) 14.2 mA. (D) 24.2 mA.
53. The transistor used in a portion of the TTL gate shown in the figure have a  $\beta = 100$ . The base-emitter voltage of is 0.7V for a transistor in active region and 0.75V for a transistor in saturation. If the sink current  $I = 1\text{mA}$  and the output is at logic 0, then the current  $I_R$  will be equal to

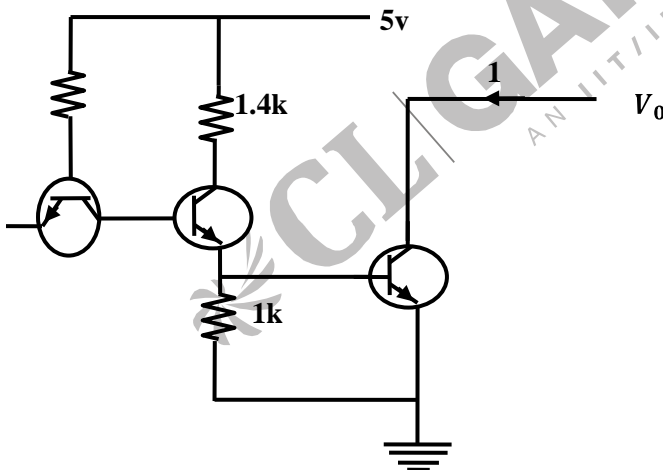

- (A) 0.65 mA. (C) 0.75 mA.  
 (B) 0.70 mA. (D) 1.00 mA
54. The Boolean expression for the truth table shown is

A	B	C	F
0	0	0	0
0	0	1	0

0	1	0	0
0	1	1	1
1	0	0	0
1	0	1	0
1	1	0	1
1	1	1	0

(A)  $B(A + C)(\bar{A} + \bar{C})$

(B)  $B(A + \bar{C})(\bar{A} + C)$

(C)  $\bar{B}(A + \bar{C})(\bar{A} + C)$

(D)  $\bar{B}(A + C)(\bar{A} + \bar{C})$

55. Both transistors  $T_1$  and  $T_2$  shown in the figure, have a threshold voltage of 1 Volt. The device parameters  $K_1$  and  $K_2$  of  $T_1$  and  $T_2$  are, respectively,  $36\mu\text{A}/\text{V}^2$  and  $9\mu\text{A}/\text{V}^2$ . The output voltage  $V_0$  is

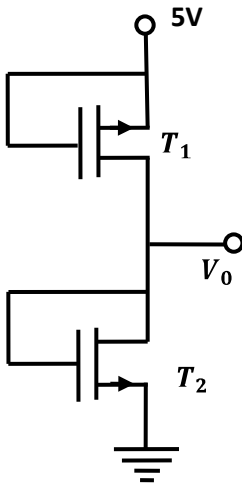

(A) 1 V

(B) 2 V

(C) 3 V

(D) 4 V

56. The present output  $Q_n$  of an edge triggered JK flip-flop is logic 0. If  $J = 1$ , then  $Q_{n+1}$
- (A) cannot be determined (C) will be logic 1  
 (B) will be logic 0 (D) will race around

57. The given figure shows a ripple counter using positive edge triggered flip-flops. If the present state of the counter is  $Q_2 Q_1 Q_0 = 011$ , then its next state ( $Q_2 Q_1 Q_0$ ) will be

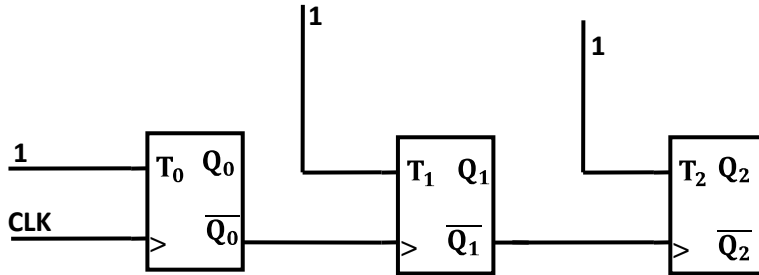

- (A) 010
- (B) 100
- (C) 111
- (D) 101

58. What memory address range is NOT represented by chip #1 and chip #2 in the figure  $A_0$  to  $A_{15}$  in this figure are the address lines and CS means Chip Select.

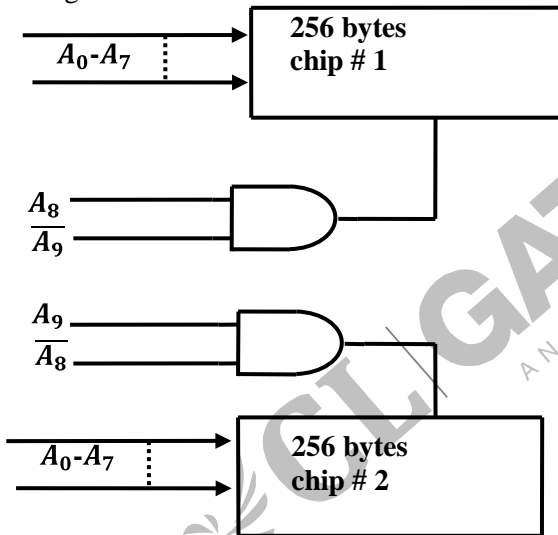

- (A) 0100–02FF
- (B) 1500–16FF
- (C) F900–FAFF
- (D) F800–F9FF

59. The output  $y(t)$  of a linear time invariant system is related to its input  $x(t)$  by the following equation:  $y(t) = 0.5x(t - t_d + T) + x(t - t_d) + 0.5x(t - t_d - T)$ . The filter transfer function  $H(\omega)$  of such a system is given by

- (A)  $(1 + \cos \omega T)e^{-j\omega t_d}$
- (B)  $(1 + 0.5 \cos \omega T)e^{-j\omega t_d}$
- (C)  $(1 + \cos \omega T)e^{-j\omega t_d}$
- (D)  $(1 - 0.5 \cos \omega T)e^{-j\omega t_d}$

60. Match the following and choose the correct combination:

**Group 1**

E. continuous and aperiodic signal

F. continuous and periodic signal

G. Discrete and aperiodic signal

H. Discrete and periodic signal

(A) E-3, F-2, G-4, H-1

(B) E-1, F-3, G-2, H-4

**Group 2**

1. Fourier representation is continuous and aperiodic

2. Fourier representation is discrete and aperiodic

3. Fourier representation is continuous and periodic

4. Fourier representation is discrete and periodic

(C) E-1, F-2, G-3, H-4

(D) E-2, F-1, G-4, H-3

61. A signal  $x(n] = \sin(\omega_0 n + \phi)$  is the input to a linear time-invariant system having a frequency response  $H(e^{j\omega})$ . If the output of the system is  $Ax(n-n_0)$ , then the most general form of  $\angle H(e^{j\omega})$  will be.

(A)  $-n_0\omega_0 + \beta$  for any arbitrary real  $\beta$ .

(B)  $-n_0\omega_0 + 2\pi k$  for any arbitrary integer

k.

(C)  $n_0\omega_0 + 2\pi k$  for any arbitrary integer

(D)  $-n_0\omega_0\phi$

62. For a signal  $x(t)$  the fourier transform is  $X(f)$ . Then the inverse Fourier transform of  $X(3f + 2)$  is given by

(A)  $\frac{1}{2} \left(\frac{t}{2}\right) e^{j3\pi t}$

(B)  $\frac{1}{3x} \left(\frac{t}{3}\right) e^{-4j\pi t/3}$

(C)  $3x(3t) e^{-j4\pi t}$

(D)  $x(3t + 2)$

63. The polar diagram of a conditionally stable system for open loop gain  $K = 1$  is shown in the figure. The open loop transfer function of the system is known to be stable. The closed loop system is stable for

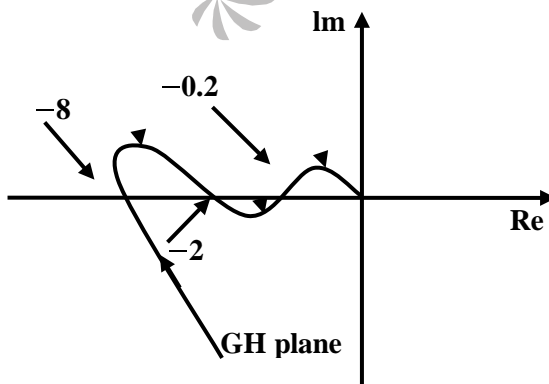

- (A)  $K < 5$  and  $\frac{1}{2} < K < \frac{1}{8}$ .  
 (B)  $K < \frac{1}{8}$  and  $\frac{1}{2} < K < 5$ .  
 (C)  $K < \frac{1}{8}$  and  $5 < K$ .  
 (D)  $K > \frac{1}{8}$  and  $K < 5$ .

64. In the derivation of expression for peak percent overshoot,  $M_p = \exp\left(\frac{-\pi\zeta}{\sqrt{1-\zeta^2}}\right) \times 100\%$ , which one of the following conditions is NOT required?

- (A) System is linear and time invariant.  
 (B) The system transfer function has a pair of complex conjugate poles and no zeroes  
 (C) There is no transportation delay in the system.  
 (D) The system has zero initial conditions.

65. Given the ideal operational amplifier circuit shown in the figure indicate the correct transfer characteristics assuming ideal diodes with zero cut-in voltage.

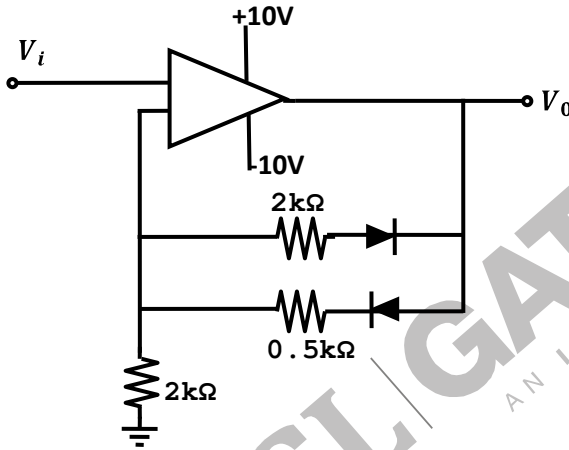

(A)

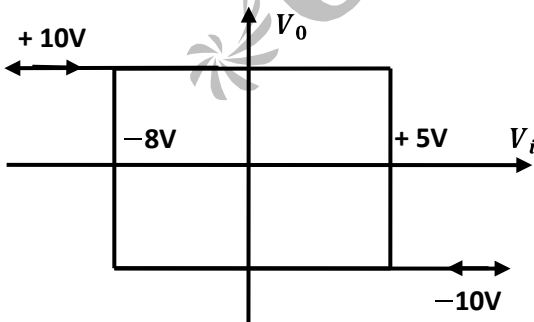

(B)

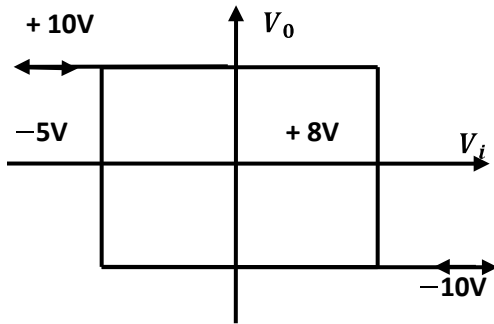

(C)

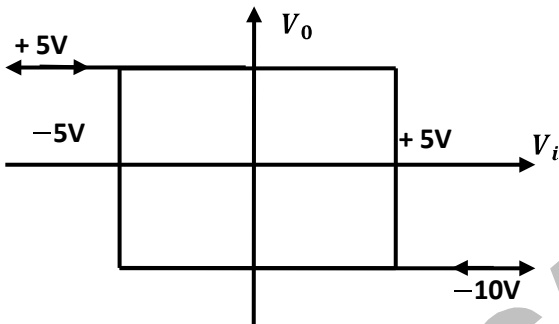

(D)

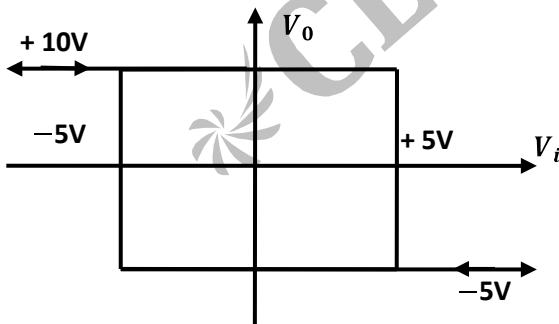

66. A ramp input applied to an unity feedback system results in 5% steady state error. The type number and zero frequency gain of the system are respectively

- (A) 1 and 20
- (B) 0 and 20
- (C) 0 and  $\frac{1}{20}$
- (D) 1 and  $\frac{1}{20}$

67. A double integrator plant,  $G(s) = \frac{K}{s^2}$ ,  $H(s) = 1$  is to be compensated to achieve the damping ratio  $\zeta=0.5$ , and an undamped natural frequency,  $\omega_n= 5$  rad/s. Which one of the following compensator  $G_e(s)$  will be suitable?

- (A)  $\frac{s+3}{s+9.9}$
- (B)  $\frac{s+9.9}{s+3}$
- (C)  $\frac{s-6}{s+8.33}$
- (D)  $\frac{s-6}{s}$

68. An unity feedback system is given as,  $G(s) = \frac{K(1-s)}{s(s+3)}$  Indicate the correct root locus diagram.

(A)

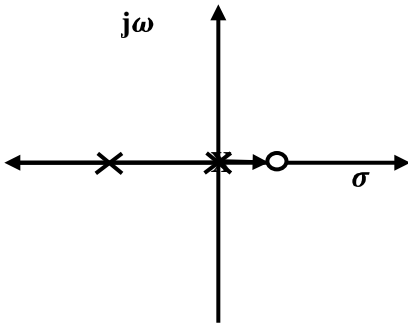

(B)

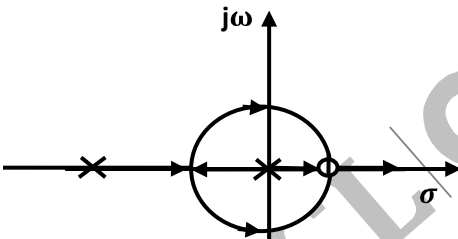

(C)

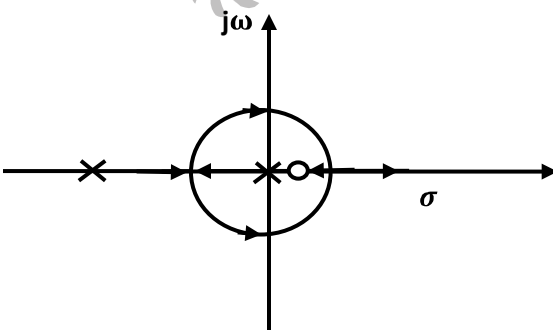

(D)

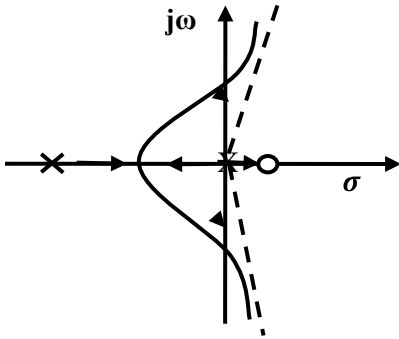

69. A MOS capacitor made using p type substrate is in the accumulation mode. The dominant charge in the channel is due to the presence of

- (A) holes  
(B) electrons  
(C) positively charged ions  
(D) negatively charged ions

70. A device with input  $x(t)$  and output  $y(t)$  is characterized by:

$$y(t) = x^2(t).$$

An FM signal with frequency deviation of 90 kHz and modulating signal bandwidth of 5 kHz is applied to this device. The bandwidth of the output signal is

- (A) 370 kHz  
(B) 190 kHz  
(C) 380 kHz  
(D) 95 kHz

71. A signal as shown in the figure is applied to a matched filter. Which of the following does represent the output of this matched filter?

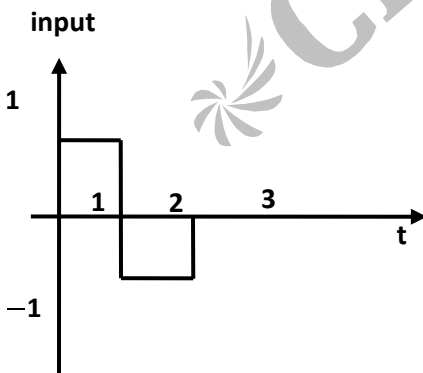

(A)

Output

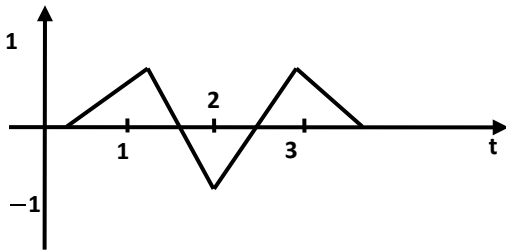

(B)

Output

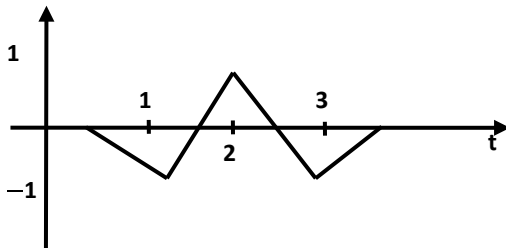

(C)

Output

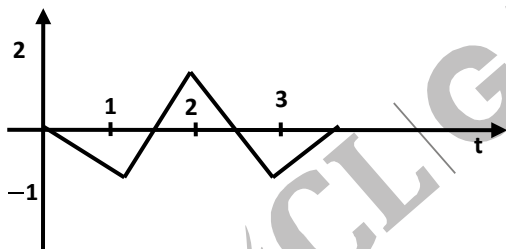

(D)

Output

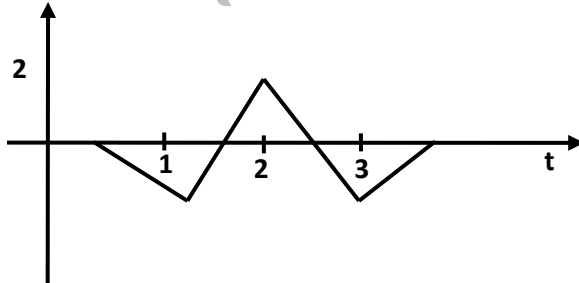

CL GATEaspire

AN IIT/IISc ALUMNI VENTURE

72. Noise with uniform power spectral density of  $N_0$  W/Hz is passed through a filter  $H(\omega) = 2 \exp(-j\omega t_d)$  followed by an ideal low pass filter of bandwidth  $B$  Hz. The output noise power in Watts is

- (A)  $2 N_0 B$  (C)  $8 N_0 B$   
 (B)  $4 N_0 B$  (D)  $16 N_0 B$

73. A carrier is phase modulated (PM) with frequency deviation of 10 kHz by single tone frequency of 1 kHz. If the single tone frequency is increased to 2 kHz, assuming that phase deviation remains unchanged, the bandwidth of the PM signal is

- (A) 21 kHz. (C) 42 kHz  
 (B) 22 kHz (D) 44 kHz

74. An output of a communication channel is a random variable  $v$  with the probability density function as shown in the figure The mean square value of  $v$  is

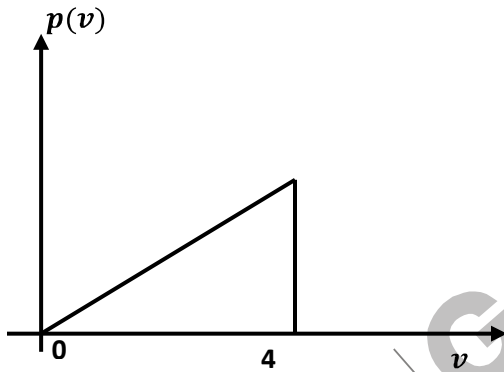

- (A) 4 (C) 8  
 (B) 6 (D) 9

75. Which one of the following does represent the electric field lines for the  $TE_{02}$  mode in the cross-section of a hollow rectangular metallic waveguide?

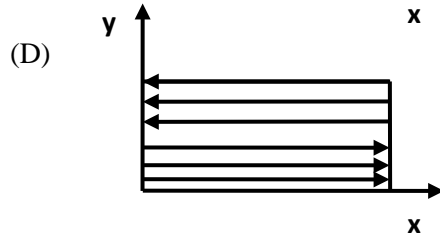
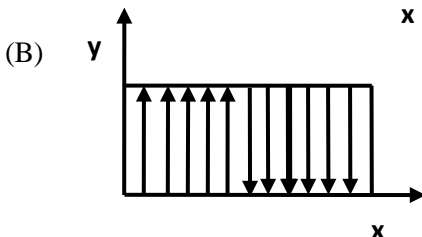
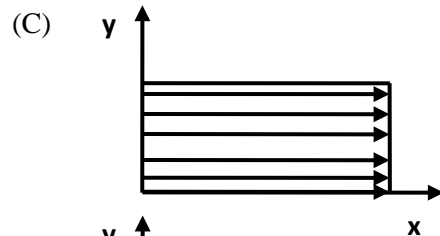
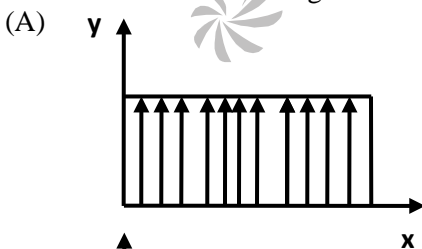

76. Characteristic impedance of a transmission line is  $50\Omega$ . Input impedance of the open-circuited line is  $Z_{oc} = 100 + j150\Omega$ . When the transmission line is short-circuited, then value of the input impedance will be

- (A)  $50\Omega$
- (B)  $100 + j150\Omega$
- (C)  $7.69 + j11.54\Omega$
- (D)  $7.69 - j11.54\Omega$

77. Two identical and parallel dipole antennas are kept apart by a distance of  $\frac{\lambda}{4}$  in the H-plane. They are fed with equal currents but the right most antenna has a phase shift of  $+90^\circ$ . The radiation pattern is given as

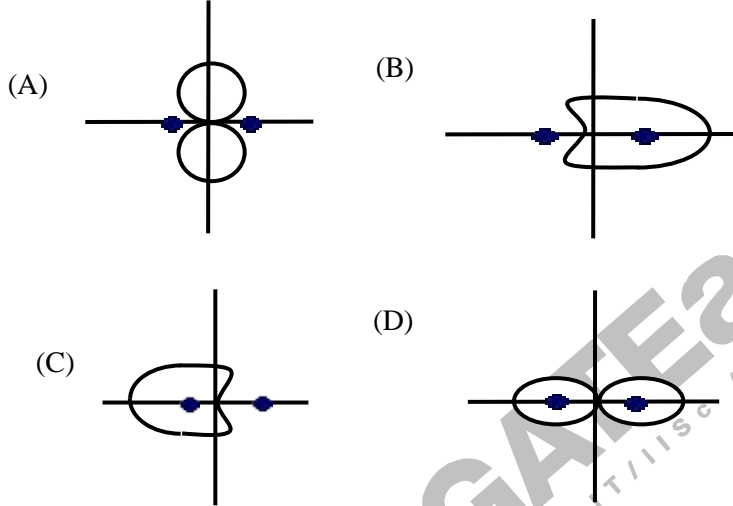

**Common Data Question 78, 79, 80**

Given,  $r_d = 20\text{ k}\Omega$ ,  $I_{DSS} = 10\text{ mA}$ ,  $V_p = -8\text{ V}$

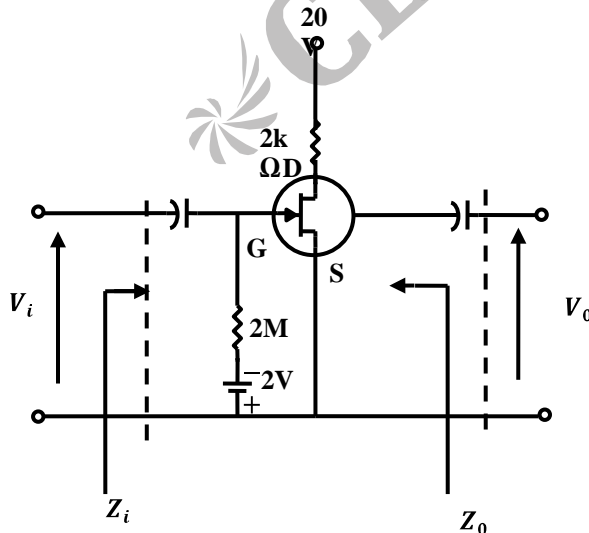

78.  $Z_i$  and  $Z_o$  of the circuit are respectively  
 (A)  $2\text{ M}\Omega$  and  $2\text{ k}\Omega$  (C) infinity and  $2\text{ k}\Omega$   
 (B)  $2\text{ M}\Omega$  and  $\frac{20}{11}\text{ k}\Omega$  (D) infinity and  $\frac{20}{11}\text{ k}\Omega$
79.  $I_D$  and  $V_{DS}$  under DC conditions are respectively  
 (A)  $5.625\text{ mA}$  and  $8.75\text{ V}$  (C)  $4.500\text{ mA}$  and  $11.00\text{ V}$   
 (B)  $7.500\text{ mA}$  and  $5.00\text{ V}$  (D)  $6.250\text{ mA}$  and  $7.50\text{ V}$
80. Transconductance in milli–Siemens(mS) and voltage gain of the amplifier are respectively  
 (A)  $1.875\text{ mS}$  and  $3.41$  (C)  $3.3\text{ mS}$  and  $-6$   
 (B)  $1.875\text{ mS}$  and  $-3.41$  (D)  $3.3\text{ mS}$  and  $6$

**Linked Answer Questions: Q. 81a to 85b Carry Two Marks Each**

**Statement for Linked Answer Question 81a and 81b:**

Consider an 8085 microprocessor system

81. a. The following program starts at location 0100H.

LXI SP, 00FF

LXI H, 0701

MVI A, 20H

SUB M

The content of accumulator when the program counter reaches 0109H is

- (A) 20H (C) 00H  
 (B) 02H (D) FFH
81. b. If in addition following code exists from 019H onwards,  
 ORI 40 H  
 ADD M  
 What will be the result in the accumulator after the last instruction is executed?  
 (A) 40H (C) 60H  
 (B) 20H (D) 42H

**Statement for Linked Answer Questions 82a and 82b:**

The dopen loop transfer function of a unity feedback system is given by  $G(s) = \frac{3e^{-2}}{s(s+2)}$

82. a. The gain and phase crossover frequencies in rad/sec are, respectively  
 (A) 0.632 and 1.26 (C) 0.485 and 0.632  
 (B) 0.632 and 0.485 (D) 1.26 mA and 0.632 V
82. b. Based on the above results, the gain and phase margins of the system will be  
 (A)  $-7.09$  and  $87.5^\circ$  (C)  $7.09\text{ dB}$  and  $-87.5^\circ$   
 (B)  $7.09$  and  $87.5^\circ$  (D)  $-7.09\text{ dB}$  and  $-87.5^\circ$

**Statement for Linked Answer Question 83a and 83b**

Asymmetric three-level midtread quantizer is to be designed assuming equiprobable occurrence of all quantization levels.

83. a. If the probability density function is divided into three regions as shown in the figure, the value of  $a$  in the figure is

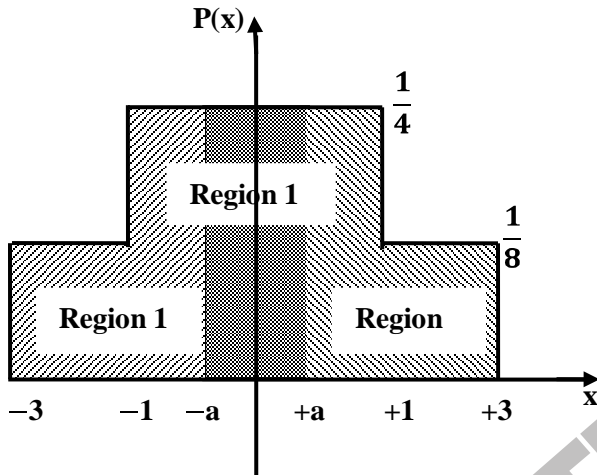

- (A)  $\frac{1}{3}$   
 (B)  $\frac{2}{3}$   
 (C)  $\frac{1}{2}$   
 (D)  $\frac{1}{4}$
83. b. The quantization noise power for the quantization region between  $-a$  and  $+a$  in the figure is
- (A)  $\frac{4}{81}$  (C)  $\frac{5}{81}$   
 (B)  $\frac{1}{9}$  (D)  $\frac{2}{81}$

**Statement for Linked Answer Question 84a and 84b**

Voltage standing wave pattern in a lossless transmission line with characteristic impedance 50W and a resistive load is shown in the figure.

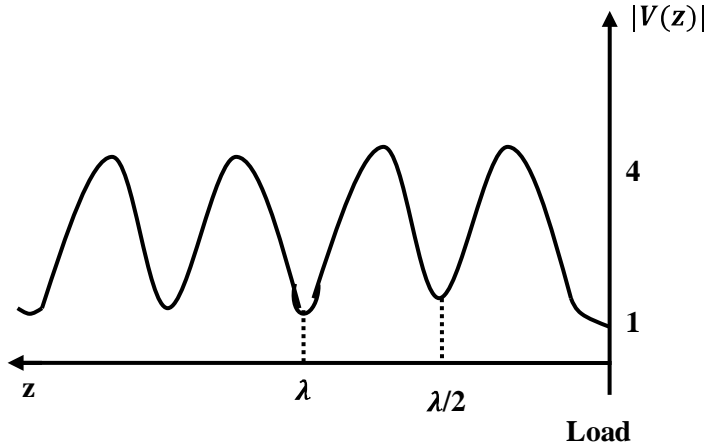

84. a. The value of the load resistance is

- (A)  $50\Omega$
- (B)  $200\Omega$
- (C)  $12.5\Omega$
- (D)  $0\Omega$

84. b. The reflection coefficient is given by

- (A)  $-0.6$
- (B)  $-1$
- (C)  $0.6$
- (D)  $0$

**Statement for Linked Answer Question 85a and 85b**

A sequence  $x(n)$  has non-zero values as shown in the figure

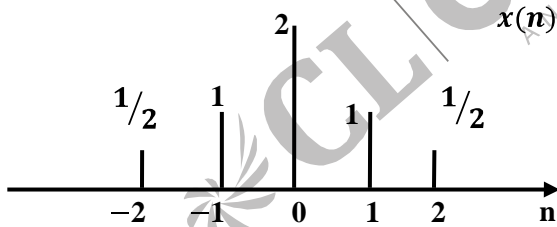

85. a. The sequence  $y(n) = \begin{cases} x(\frac{n}{2} - 1) & \text{for } n \text{ even} \\ 0 & \text{for } n \text{ odd} \end{cases}$  will be

(A)

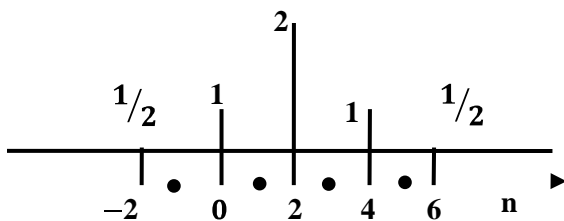

(B)

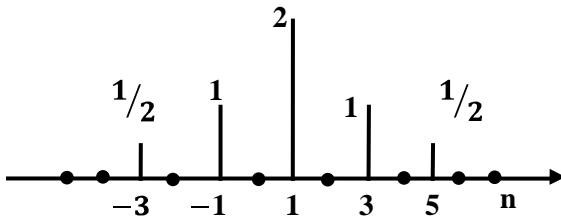

(C)

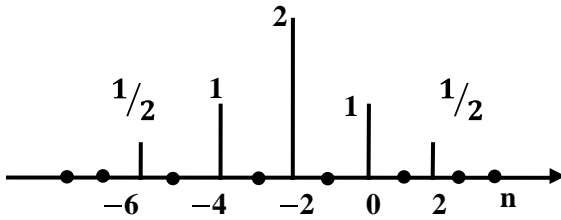

(D)

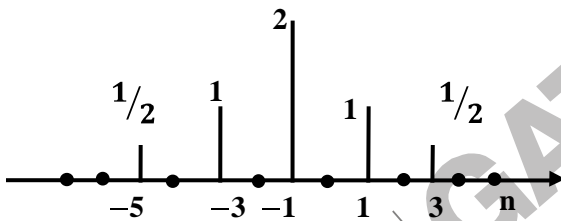

85. b. The Fourier transform of  $y(2n)$  will be

- (A)  $e^{-j2\omega} [\cos 4\omega + 2\cos 2\omega + 2]$
- (B)  $[\cos 2\omega + 2\cos \omega + 2]$
- (C)  $e^{-j\omega} [\cos 2\omega + 2\cos \omega + 2]$
- (D)  $e^{-j2\omega} [\cos 2\omega + 2\cos \omega + 2]$